

Hallmark Oil Fired Furnace

Installation and Operation Instruction
Manual

Variable Speed 2 Stage
ECM Motor



Keep these instructions with the furnace at all times
for future reference

Boyertown Furnace Co.
PO Box 100
Boyertown, PA 19512
610-369-1450
www.boyertownfurnace.com

Be Aware of Hazard Definitions

Danger

Denotes presence of a hazard which, if ignored, will result in severe personal injury, death or property damage

Warning

Denotes presence of a hazard which, if ignored could result in severe personal injury, death or substantial property damage.

Caution

Denotes the presence of a hazard, which if ignored, could result in minor personal injury or property damage

Notice

Intended to bring attention to information, but not related to personal injury or property damage.

Danger

This equipment must be installed, adjusted and started only by a qualified service agency – an individual or agency, licensed and experienced with all codes and ordinances, and who is responsible for the installation and adjustment of the equipment. The installation must comply with all local codes and ordinances and with the latest revision of the National Fire Protection Standard for Oil Burning Equipment, NFPA 31.

Read all instructions before proceeding. Follow all instructions completely. Failure to follow these instructions could result in equipment malfunction causing severe personal injury, death or substantial property damage.

Do not alter this furnace in any way. The manufacturer will not be liable for any damage resulting from changes made in the field to the furnace or its components or from improper installation. Failure to comply could result in severe personal injury, death, or substantial property damage.

Your oil fired furnace is designed to burn No. 1 and No. 2 heating oil only. Never use gasoline or a mixture of gasoline and oil.

Do not store gasoline or other flammable vapors and liquids in the vicinity of this or any other appliance.

The area around the furnace should be kept free and clear of combustible materials.

Never burn garbage or refuse in your furnace.

Never try to ignite oil by tossing burning papers or other material into your furnace.

Do not attempt to start the burner when excess oil has accumulated or the furnace is full of vapors.

Do not use the furnace as a construction heater.

Do not operate furnace if the heat exchanger is damaged. Toxic flue products could enter air stream.

Do not jumper, attempt to bypass or override any of the safety limit controls.

Do not use this furnace if any part has been under water. Immediately call a qualified service technician to inspect the furnace and replace any part of the furnace, control system or burner that has been under water.

Do not operate furnace if temperature rise through the heat exchanger exceeds that which is listed on the Ratings Label (Typically 75°F).

Do not operate furnace without return air properly sized or ducted.

NOTICE

Concealed Damage- If you discover damage to the burner, furnace or controls during unpacking, notify the carrier at once and file the appropriate claim. When calling or writing about the furnace please have the following information available: the furnace model number and serial number which is located on the upper portion of the front of the unit. Record the model and serial number for future reference in the space provided in this manual.

TABLE OF CONTENTS

Page No.

| | |
|--|----|
| Furnace Specifications | 4 |
| Installation Clearances | 5 |
| Standard Clearances | |
| Reduced Clearances | |
| Duct Work | 7 |
| Sizing | |
| Blower Specifications | |
| Filter Racks | |
| Multiple Furnace Installation | |
| ECM Motor | 9 |
| Operating Modes | |
| Air Flow Selection | |
| Electrical Connections | |
| Venting | 11 |
| Chimney Venting | |
| Chimney Relining | |
| Chimney Connector | |
| Power Venting | |
| Vent Dampers | |
| Ventilation and Combustion Air | 14 |
| Burner Installation | 15 |
| Wiring | 16 |
| Power | |
| Thermostat | |
| Oil Tank and Piping | 19 |
| Start Up | 20 |
| Start Up Equipment | |
| Burner Adjustments | |
| Operating and Maintenance | 22 |
| Cleaning the Furnace | |
| Oil Burner | |
| Blowers Belt Drive | |
| Blowers Direct Drive | |
| Vent System | |
| Fuel Oil System | |
| Filters | |
| Parts Breakdown Lists | 24 |
| Trouble Shooting Guide | 26 |
| Warranty | 29 |
| Installation and Service Check List | 30 |
| Warranty Registration | 32 |

| Hallmark Specifications | | | | | | | | |
|-----------------------------|---------|---------|---------|---------|---------|---------|---------|---------|
| Model | LBD85 | LBD115 | LBD145 | LBD160 | HBD85 | HBD115 | HBD145 | HBD160 |
| BTU/Hr Input | 105,000 | 140,000 | 175,000 | 189,000 | 105,000 | 140,000 | 175,000 | 189,000 |
| BTU/Hr Output | 88,000 | 115,000 | 145,000 | 157,000 | 86,000 | 114,000 | 145,000 | 155,000 |
| Flue Size | 6" | 6" | 8" | 8" | 6" | 6" | 8" | 8" |
| AFUE Seasonal Efficiency | 82.6% | 80.0% | 83.2% | 82.9% | 81.4% | 80.7% | 83.9% | 82.9% |
| Filter Size (inches) | 16x20 | 20x20 | 1-16x20 | 1-16x20 | 16x20 | 20x20 | 20x25 | 20x25 |
| | | | 1-20x20 | 1-20x20 | | | | |
| Heating CFM | 1175 | 1500 | 1875 | 2050 | 1175 | 1500 | 1875 | 2050 |
| Cooling CFM Max | 1400 | 1600 | 2000 | 2000 | 1400 | 1600 | 2000 | 2000 |
| Cooling Capacity (Tons) Max | 3 1/2 | 4 | 5 | 5 | 3 1/2 | 4 | 5 | 5 |
| Shipping Weight (lbs) | 385 | 435 | 485 | 485 | 350 | 400 | 450 | 450 |
| Dimensions (Inches) | | | | | | | | |
| Cabinet Height | A 42 | 45 | 45 | 45 | 55 | 60 | 60 | 60 |
| Cabinet Width | B 23 | 24 | 24 | 24 | 23 | 24 | 24 | 24 |
| Cabinet Depth | C 38 | 42 | 53 | 53 | 22 | 22 | 29 5/8 | 29 5/8 |
| Center Line Flue to Floor | D35 1/2 | 38 1/2 | 37 1/2 | 37 1/2 | 48 1/2 | 53 1/2 | 52 1/2 | 52 1/2 |
| Center Line Flue to Side | E11 1/2 | 12 | 12 | 12 | 11 1/2 | 12 | 12 | 12 |
| Depth of Burner Housing | F 10 | 10 | 10 | 10 | 10 | 10 | 10 | 10 |
| Warm Air Supply Depth | G 20 | 20 | 27 5/8 | 27 5/8 | 20 | 20 | 27 5/8 | 27 5/8 |
| Warm Air Supply Width | Ho 21 | 22 | 22 | 22 | 21 | 22 | 22 | 22 |
| Return Air Width | Hr 21 | 22 | 22 | 22 | 15 | 18 7/8 | 18 7/8 | 18 7/8 |
| Return Air Depth | J14 1/8 | 18 1/8 | 21 1/2 | 21 1/2 | 18 7/8 | 18 7/8 | 23 7/8 | 23 7/8 |

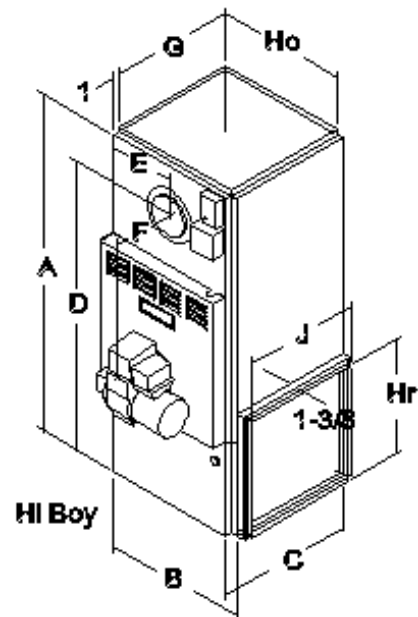
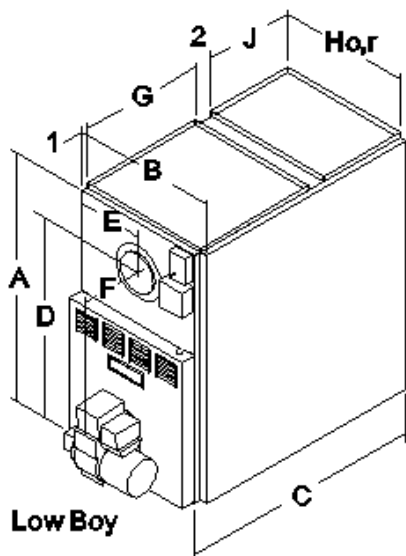

Installation Clearances

WARNING Furnaces in rooms shall be installed with the clearances from combustible materials not less than indicated in Table 1. Combustible materials are those made of or surfaced with wood, compressed paper, plant fibers, plastics, or other material that will ignite and burn, whether flame proofed or not, or whether plastered or not.

Place the furnace near the center of the supply and return ducts and as close to the chimney connector as possible. Provide a solid brick or 2” thick minimum concrete pad if the furnace mounting area is not level or if the floor can become flooded.

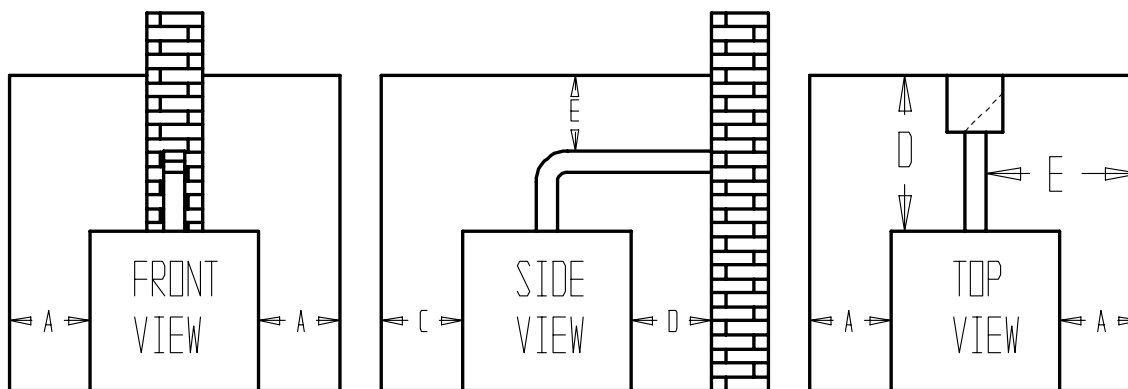

Table 1 Standard Installation Clearances

| MODEL | Sides “A” | Top “B” | Front “C” | Rear “D” | Flooring | Chimney Connector “E” | Plenum Top & Sides |
|---------|--------------|------------|--------------|-------------|-------------|-----------------------------|--------------------------|
| HBD 85 | 6” | 2” | 24” | 6” | Combustible | 18” | 2” |
| LBD 85 | 6” | 2” | 24” | 6” | Combustible | 18” | 2” |
| HBD 115 | 6” | 2” | 24” | 6” | Combustible | 18” | 2” |
| LBD 115 | 6” | 2” | 24” | 6” | Combustible | 18” | 2” |

Lowboy furnaces not listed for combustible floor may be placed on combustible floors although not listed for such installation, provided the floor under the furnace is protected in accordance with the requirements of accepted building code practice and NFPA 31. The furnaces shall be permitted to be placed on combustible flooring protected by 4” hollow block placed with ends unsealed and joints matching in such a fashion as to permit free circulation of air from side to side through the masonry. The block must be covered with sheet metal not less than 24 gauge.

Furnaces are permitted to be installed in rooms, but not alcoves or closets, with lesser clearances to combustible material, provided the combustible material is protected as described in Table 2 and NFPA 31. In no case shall the clearance be such as to interfere with the requirements for combustion air, draft regulators and accessibility.

All clearances shall be measured from the outer surface of the combustible material to the nearest point on the surface of the appliance or chimney connector, disregarding any intervening protection applied to the combustible material.

Spacers and ties are to be of noncombustible material. No spacer or tie shall be used directly opposite an appliance or chimney connector.

With all clearance reduction systems using ventilated air space there shall be at least 1" clearance between the reduction systems using ventilated air space.

Mineral wool batts, blanket or board shall have a minimum density of 8lb/ft³ and a minimum melting temperature of 1500⁰F.

Insulation material used as part of a clearance reduction system shall have a thermal conductivity of 1.0(Btu/In)/ (Ft²/Hr/⁰F).

| Type of protection applied to and covering all surfaces within the distance specified as the required clearance with no protection | Table 2 Allowable Clearances with Specified Protection Where the Specified Clearance with No Protection from the Appliance or Chimney Connector | | | | | | | |
|--|---|--------------|-------|--------------|-------|--------------|-------|--------------|
| | 18" | | 12" | | 9" | | 6" | |
| | Above | Rear & Sides | Above | Rear & Sides | Above | Rear & Sides | Above | Rear & Sides |
| 3½" thick masonry wall without ventilated air space | N/A | 12" | N/A | 9" | N/A | 6" | N/A | 5" |
| ½" insulation board over 1" glass fiber or mineral wool batts | 12" | 9" | 9" | 6" | 6" | 5" | 4" | 3" |
| 24 gauge sheet metal over 1" glass fiber or mineral wool batts reinforced with wire on rear face with ventilated air space | 9" | 6" | 6" | 4" | 5" | 3" | 3" | 3" |
| 3½" thick masonry wall with ventilated air space | N/A | 6" | N/A | 6" | N/A | 6" | N/A | 6" |
| 24 gauge sheet metal with ventilated air space | 9" | 6" | 6" | 4" | 5" | 3" | 3" | 2" |
| ½" insulation board with ventilated air space | 9" | 6" | 6" | 4" | 5" | 3" | 3" | 3" |
| 24 gauge sheet metal with ventilated air space over 24 gauge sheet metal with ventilated air space | 9" | 6" | 6" | 4" | 5" | 3" | 3" | 3" |
| 1" glass fiber or mineral wool batts sandwiched between 2 sheets 24 gauge sheet metal with ventilated air space | 6" | 6" | 6" | 4" | 5" | 3" | 3" | 3" |

If the furnace is to be installed in a residential garage, the furnace must be a minimum of 18" above the garage floor and located so it cannot be damaged by a moving vehicle

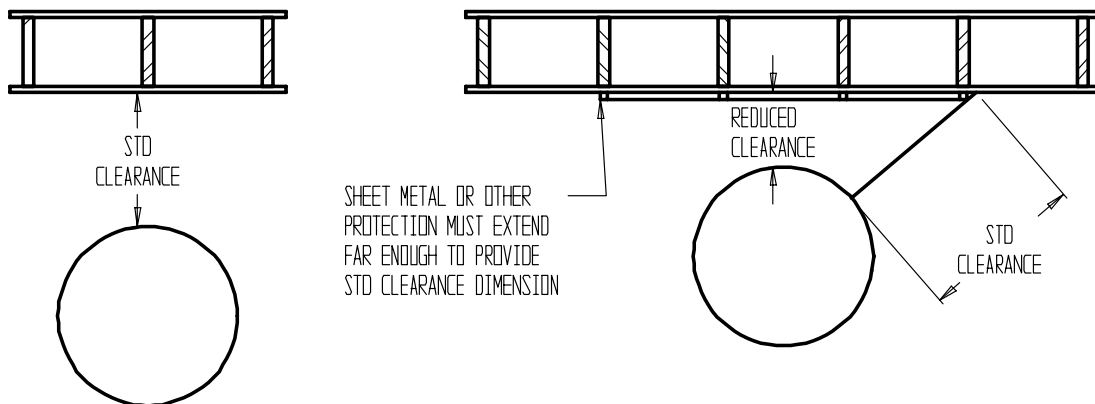

Duct Work

NOTICE

The duct system should follow the design standards of Air Conditioning Contractors of America (ACCA) or ASHRAE. The duct system should be sized for the maximum CFM capabilities of the furnace being installed.

All trunk lines, take-offs, registers and grill free areas must be figured when determining the air handling capacity of a duct system. By utilizing the Tables 3 through 5, one can obtain the necessary duct system size. Use a supplier's catalog for proper sizing of outlet and return air registers to insure that the register will meet the CFM requirements of the run to which it is connected. Do not exceed the recommended flow rate. The pressure drop for each should not exceed 0.05 inch water column.

The return air ducts should equal the warm air duct system in CFM capacities. Avoid locating a return air duct in rooms that may contain undue odors. Use only a return air filter mounted to or integral to the furnace. Do not add additional filters unless the duct system is sized to allow for the additional pressure drop. **An open return in a basement does not meet the requirements of return air. Instruct the homeowner not to block any returns.**

Always check the size of existing ducts, particularly if you are adding air conditioning. The pressure drop through the cooling evaporator coil reduces available air flow. If the ducts are too small the system may not work satisfactorily or be noisy on either heat or cooling.

If the furnace is used in connection with summer air conditioning, the furnace should be installed parallel with or on the upstream side of the evaporator coil to avoid condensation in the furnace heat exchanger. The evaporator coil must be installed at least 6" above the heat exchanger for proper air flow. Distances less than 6" will result in decreased air flow. In all cases refer to the manufacturers data for static pressure losses to ensure the total system static pressure does not exceed 0.5" WC. If the cooling unit is installed with a parallel flow arrangement, dampers or other means used to control flow of air should be provided to prevent chilled air from entering the furnace. If such a damper is manually operated, it must be equipped with a means to prevent operation of either unit, unless the damper is in the full heat or cool position.

NOTE: When a return register is located in the same room as the furnace, the register must be at least 20 feet away from the furnace.

Determining Air Flow CFM

The temperature rise through the furnace should not exceed the rated temperature rise as listed on the Rating Label (Typically 75°F) and should be at least 55°F for comfort.

The sensible heat temperature change for cooling would be approximately 30°F. Actual temperature change will be approximately 20°F due to the humidity in the air.

To calculate the sensible heat change or temperature rise the following formula applies

$$\Delta T = (\text{Btuh} - \text{Output}) / (1.1 \times \text{CFM})$$

To calculate the air flow when you know the temperature rise the following formula applies

$$\text{CFM} = (\text{Btuh} - \text{Output}) / (1.1 \times \Delta T)$$

An estimate of air flow can be achieved by the following rules of thumb:

Heating: 1300 CFM per 100,000 Btuh output

Cooling: 400 CFM per ton of air conditioning

Determine the required air flow for the system based on both heating and cooling requirements. Use the larger of either for duct design.

Table 3 lists the maximum recommended air velocities for ducts. Velocities greater than those as

listed may result in objectionable air noise in the ducts.

| Table 3 Recommended Maximum Duct Velocities, Feet Per Minute (FPM) | | | | |
|--|-------------|--------|--------------|--------|
| Application | Main Ducts* | | Branch Ducts | |
| | Supply | Return | Supply | Return |
| Apartments | 900 | 700 | 600 | 600 |
| Auditoriums | 1200 | 1000 | 1000 | 800 |
| Banks | 2000 | 1500 | 1600 | 1200 |
| Hotel Rooms | 1500 | 1300 | 1200 | 1000 |
| Libraries | 2000 | 1500 | 1600 | 1200 |
| Meeting Rooms | 2000 | 1500 | 1600 | 1200 |
| Offices | 2000 | 1500 | 1600 | 1200 |
| Residences | 900 | 700 | 600 | 600 |
| Restaurants | 2000 | 1500 | 1600 | 1200 |
| Retail Stores | 2000 | 1500 | 1600 | 1200 |

*When sound control is critical use branch duct velocities

| Table 4 Duct Area Required at Listed Flow Conditions | | | | | | |
|--|---------------------------|---------------------------|----------------------------|----------------------------|----------------------------|----------------------------|
| CFM | Area Sq. In. 600FPM | Area Sq. In. 800FPM | Area Sq. In. 1000FPM | Area Sq. In. 1200FPM | Area Sq. In. 1600FPM | Area Sq. In. 2000FPM |
| 50 | 12 | | | | | |
| 100 | 24 | 18 | 14 | 12 | | |
| 150 | 36 | 27 | 22 | 18 | 14 | |
| 200 | 48 | 36 | 29 | 24 | 18 | 14 |
| 250 | 60 | 45 | 36 | 30 | 23 | 18 |
| 300 | 72 | 54 | 43 | 36 | 27 | 22 |
| 400 | 96 | 72 | 58 | 48 | 36 | 29 |
| 500 | 120 | 90 | 72 | 60 | 45 | 36 |
| 750 | 180 | 135 | 108 | 90 | 68 | 54 |
| 1000 | 240 | 180 | 144 | 120 | 90 | 72 |
| 1250 | 300 | 225 | 180 | 150 | 113 | 90 |
| 1500 | 360 | 270 | 216 | 180 | 135 | 108 |
| 1750 | 420 | 315 | 252 | 210 | 158 | 126 |
| 2000 | 480 | 360 | 288 | 240 | 180 | 144 |

Note: For Systems not over 100 feet equivalent length. Do not apply this table to duct systems which exceed 100 equivalent feet in length. For longer systems refer to ACCA Manual D. Incorrectly sized ducts can result in unsafe or uncomfortable operation.

| Table 5 Round Duct Equivalent Area | | | | | | | | |
|------------------------------------|------|------|------|------|------|------|------|-------|
| Nominal Size | 4 | 5 | 6 | 7 | 8 | 9 | 10 | 12 |
| Area in. ² | 12.5 | 19.6 | 28.3 | 38.5 | 50.3 | 63.6 | 78.5 | 113.1 |

MULTIPLE FURNACES IN COMMON DUCT WORK

WARNING

Multiple furnaces connected to common duct work, either supply, return, or both supply and return must be wired so that all furnace blower motors are energized at the same time.

Failure to turn all blowers on at the same time can cause a reversal of air flow in those units where the blower motor is not operating. This reversal of air flow can cause premature blower, blower motor, wiring and or heat exchanger failure.

Please consult the factory for specific wiring instructions for your application.

Table 6 Blower Specifications

| Model | HP | Speeds | RPM | Volts | Full Load Amp. | Rotation | Blower Model |
|-------------|-----|----------|----------|-------|----------------|----------|--------------|
| HBD/LBD 85 | 3/4 | Variable | 1400 Max | 115 | 9.6 | CCW | 100-10T |
| HBD/LBD 115 | 3/4 | Variable | 1400 Max | 115 | 9.6 | CCW | 100-10T |

ECM MOTOR OPERATING MODES

Introduction

The ECM 2.3 motor is a variable speed, high efficiency motor which has the ability to produce constant air flow within a system, independent of static pressure. It achieves constant air flow by adjusting speed and torque to account for changes in system static pressure. The GE ECM uses a proprietary mathematical algorithm to model air moving systems driven by forward curved blower wheels.

Operating Modes

The ECM motor is controlled by 24VAC thermostat signals to determine which mode of operation the blower is to run. Air flow rates in the different modes are controlled by the setting of the DIP switches.

Standby Mode:

The thermostat inputs are being continuously monitored. The motor will respond to the 24 volt AC input signal from the thermostat.

Fan Mode:

When a call for fan operation is received from the thermostat ("G" line is energized) the blower will operate at a reduced speed as determined by the position of the cooling DIP switches as set for the airconditioning speed. See air flow tables for DIP switch and air flows. If a call for cooling or for heating is energized along with the call for fan only the unit will run at the respective air flow for heating or cooling.

Cooling Mode:

When a call for cooling is received from the thermostat ("Y" line is energized) the motor will operate at the cooling speed and profile as adjusted by the cooling DIP switches. Cooling air flow is profiled to ramp the air flow up to the full cooling air flow to allow for maximum dehumidification

Heat Mode:

When a call for heat is received from the thermostat ("W" line is energized) the motor will operate through the heating cycle at the air flow as adjusted by the heating DIP switch. When a call for heat is initiated the blower will turn on after a 90 second delay to ensure warm plenum temperatures as the furnace heats up. The blower then runs at a reduced rate for 3-1/2 minutes before increasing its speed to the full air flow requirements.

When the call for heat is satisfied the blower will continue to operate at a reduced rate for a period of 3 minutes to remove all of the usable heat from the furnace while still maintaining the plenum temperatures at a comfortable level.

ECM Motor Air Flow Selection

Air flow settings for both heating and cooling are made by setting the heating and the cooling airflow DIP switches to the proper location. These DIP switches are located in the 4 x 4 junction box mounted directly under the fan center relay. Do not change the air flow settings until the blower has come to a complete stop. No change in air flow will occur unless the motor has been allowed to a complete stop.

See figure below for the location of the heating and cooling DIP switches. Hallmark 85 shown as typical.

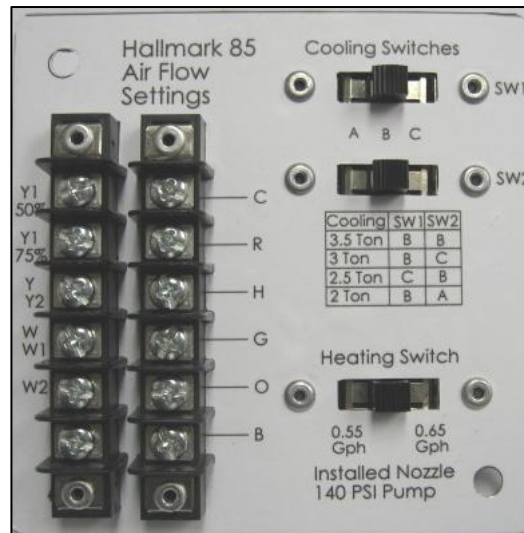

Do not adjust the heating air flow below the firing rate of the furnace. The air flows for heating are designed to give a 70°F to 75°F temperature rise.

| Burner Firing Rate | Heating Air Flow | Cooling/ Heat Pump Tonnage | Air Flow Y1-50%/Y1-75% | Air Flow Y/Y2 | Fan Only Air Flow |
|--------------------|------------------|----------------------------|------------------------|---------------|-------------------|
| 0.65 GPH | 975 CFM | 2 | 400/600CFM | 800 | 400 CFM |
| 0.75 GPH | 1175 CFM | 2-1/2 | 500/750 CFM | 1000 | 500 CFM |
| 0.85 GPH | 1275 CFM | 3 | 600/900 CFM | 1200 | 600 CFM |
| 1.00 GPH | 1500 CFM | 4 | 800/1200 CFM | 1600 | 800 CFM |

ECM Motor Connections

The operation of the motor requires two main connections: the power input connector which is 120VAC, and the signal input connector from a 24VAC thermostat. Figure 1 shows the location of the connectors on the motor. When wiring your ECM 2.3, the pin locations are crucial in assuring that no damage is done to the motor or the control. Figures 2 and 3 show the pin locations for both connectors, when viewing the motor as shown in Figure 1

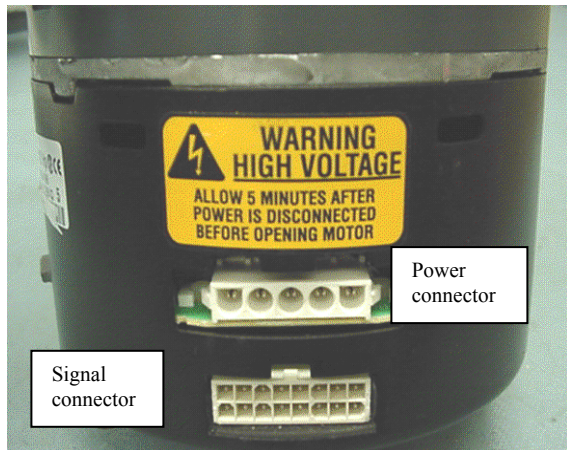
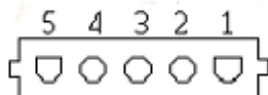

Figure 1

Figure 3 Power Connector



| Power Connector | |
|-----------------|-----------------------|
| <i>Pin</i> | <i>Description</i> |
| 1 | JUMPER PIN 1 TO PIN 2 |
| 2 | 120 VAC LINE INPUT |
| 3 | CHASSIS GROUND |
| 4 | AC LINE |
| 5 | AC LINE |

Figure 2 Signal Connector

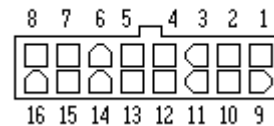

| Signal Connector | |
|------------------|--------------------|
| <i>Pin</i> | <i>Description</i> |
| 1 | C1 |
| 2 | W/W1 |
| 3 | C2 |
| 4 | DELAY |
| 5 | COOL |
| 6 | Y1 |
| 7 | ADJUST |
| 8 | OUT- |
| 9 | O |
| 10 | BK/PWM |
| 11 | HEAT |
| 12 | R |
| 13 | EM/W2 |
| 14 | Y/Y2 |
| 15 | G |
| 16 | OUT+ |

VENTING

WARNING Failure to follow all instructions can result in flue gas spillage and carbon monoxide emissions, causing severe personal injury or death. All chimneys must meet the requirements of NFPA 211 and NFPA 31

Note: For ease of installation the thermostat wiring may be attached to the air flow switch plate before attaching vent piping the furnace flue outlet.

Chimney

The furnace must be connected to an adequate chimney or an approved venting system in accordance

with these instructions. An adequate chimney or venting system is one that is sealed and lined with the capability of producing a -.04" W.C. flue draft and having the capacity to handle the amount of flue gas that is introduced. A chimney with an internal construction of corrosion resistant tile, stainless steel, or some other material that will withstand flue gas temperatures up to 1000⁰F is required.

Masonry and metal chimneys shall be constructed in accordance with applicable building code requirements. Masonry chimneys shall be lined with an approved clay tile liner or a listed chimney lining system installed in accordance with manufacturers' instructions and also meeting the requirements of NFPA-211 Standard for Chimneys, Fireplaces, Vents, and Solid Fuel-Burning Appliances. Metal chimneys also shall meet the requirements of NFPA-211. Factory built chimneys shall be listed and shall be installed in accordance with their listing and NFPA-211.

Prior to installation of the furnace, the chimney or venting system shall be examined by the installer and determined to be in good condition. All joints of the chimney must be tightly sealed. The inside of the chimney should be free of all obstruction, such as loose brick, broken pieces of tile, or corroded metal. If chimney flues are divided or there are multiple flues within one chimney, make sure there are no openings in the partition separating the divided or individual flues. When a new appliance is connected to an existing chimney, that chimney shall be brought up to current requirements. Chimneys which are relined shall be done so with an approved liner that will resist corrosion, softening, or cracking from the flue gasses.

All chimney clean-out doors and flue connections must fit tightly so they will seal to avoid air leakage.

The inside area of the chimney liner should equal, at a minimum, the area of the vent pipe exiting the furnace. If more than one appliance is installed, the area of both appliances shall be used in determining the required inside area of the chimney.

The flue gas exit of a chimney shall be at least 3 feet above the highest point where it passes through the roof of a building and at least 2 feet higher than any portion of a building within 10 feet of such chimney.

The chimney height will also be determined by the height of the surrounding trees, buildings and terrain. When chimney downdraft conditions cause faulty operation that creates a hazard, corrective steps must be taken.

When altering the surrounding obstructions is not possible, a chimney cap can be constructed on the top of the chimney to avoid downdrafts. The chimney cap should be pyramid shaped on the top with a perfectly flat surface immediately above the chimney outlet. The hood should be attached by four (4) iron supports. The four iron supports should be equal in height to the width of the chimney opening. Four plates, flaring down, can be added to help insure that the wind will pass straight over the chimney outlet.

Chimney Relining

A tile lined masonry chimney serving an oil fired furnace should comply with applicable building codes such as NFPA-211. An additional listed lining may be required to reduce transient low draft during startup and acid water condensation during cyclic operation. This is particularly true for high mass masonry chimneys serving oil fired furnaces of higher efficiency. For masonry chimneys, local experience can indicate how well construction has withstood the lower temperatures produced by higher efficiency furnaces.

Evidence of potential or existing chimney damage should be determined by visual inspection of the chimney and liner. Exterior indicators such as missing or loose mortar/bricks, white deposits on the brick or water stains on the interior building walls should be investigated further. The operational flue temperatures for furnaces range from 350°F to 550°F at the outlet of the furnace. These temperatures are further reduced before reaching the chimney due to heat loss through the vent connector and dilution from the draft regulator. The resulting flue gas temperatures may become low enough to form condensation on the chimney liner walls.

To prevent condensation, it is necessary that the internal chimney wall temperature always be kept above the dew point of the flue gasses. If the chimney is a masonry type, it may have to be lined with a flue liner, if the temperature loss is too great for the furnace. A liner will act as an insulator and reduce the flue gas temperature loss. Insulation may be added around the liner for further temperature stability. Refer to NFPA-31 for recommended liner sizing tables as developed by the Oil Heat Vent Analysis Program.

Chimney Connector

The chimney connector pipe between the furnace and chimney shall be of equal diameter as the flue outlet of the furnace. Refer to furnace specifications in this manual for proper size flue pipe for your model furnace. Any reduction in size required for the chimney must be made at the chimney connector. The vent connector pipe must be made of 24 gauge (or thicker) corrosion-resistant steel. The vent connector pipe should be as short as possible and installed so that it has a continuous rise from the furnace to the chimney. Long horizontal vent runs can result in the possibility of condensation in the flue pipe or the chimney. All horizontal runs of vent connector pipe should be pitched upward a minimum of 1/4 inch per foot of run. The horizontal length of the vent pipe connector shall not exceed 10 feet. The chimney connector shall be installed so as to minimize the number of elbows and to avoid sharp turns or other construction features that would create excessive resistance to the flow of flue gasses. Tees may be used in a straight section in conjunction with a barometric draft regulator; however, they must not be used for a 90° turn. No device that will obstruct the free flow of flue gasses shall be installed in the chimney connector. This does not exclude the use of devices specifically designed for the use in chimney connectors such as automatic dampers. The vent pipe should be joined with metal screws and supported by straps. A thimble should be used to connect the vent connector pipe to the chimney so the pipe may be readily removed in case of inspection or replacement.

No chimney connector shall pass through any floor or ceiling. The vent connector pipe must not pass through a combustible wall or partition unless they are guarded at the point of passage by a ventilated metal thimble not less than 12 inches larger in diameter than the connector, on metal or fireclay thimbles adequate protection is provided at the passageway. An acceptable passageway could be either an approved, ventilated metal thimble which is at least 12 inches larger in diameter than the vent connector pipe, or brick work which is at least 8 inches thick constructed into the wall and surrounding the vent connector

Clearances from combustible materials or materials shall be in accordance with the clearances given in Tables 1 or 2. The vent connector pipe should extend only to (and not beyond) the inside wall of the chimney. A thimble should be used to connect the vent connector pipe to the chimney so that the vent connector pipe may be readily removed in case of inspection or replacement.

Connection to the chimney must be made above the bottom of the chimney to avoid blockage. Vent piping should extend just into the chimney far enough to expel flue gasses. Inserting the vent piping too far into the chimney will cause undue obstruction. Use a thimble or a slip joint where vent pipe enters the chimney to allow easy removal for cleaning.

A draft regulator, which is shipped in the blower compartment, must be installed in the vent piping. It should be located at least 24 inches from the furnace if possible in either a horizontal or vertical section of the vent pipe. The draft regulator must be installed in the same room as the furnace and in such a manner that there is no difference in pressure between the air in the vicinity to the regulator and the combustion air supply. Ensure that the barometric damper is accessible for adjustment.

With the burner operating, use a draft gauge to adjust the regulator to the proper setting (see instructions enclosed with draft gauge to adjust the regulator to the proper setting). When the burner air supply and draft are properly adjusted, the over-fire draft should be a negative .02" W.C.

Two or more oil burning appliances each equipped with a safety control may be permitted to be connected to one common chimney if sufficient draft is available for the safe simultaneous removal of all products of combustion.

If two or more openings are provided into one chimney, they shall be at different levels on the same story of the building, with the smaller appliance entering at the highest possible level consistent with clearances to combustible materials.

Two or more connectors shall not be joined together unless the common connector, manifold and chimney are properly sized. Adequate draft must be available to safely remove all products of combustion simultaneously without leakage, or back flow.

Power Venting

The furnace may be power vented through a side wall by using a listed power side wall Venter. The vent device must be able to produce a draft of $-.02''$ W.C. over the fire and be equipped with a post purge timer set to a minimum time of 5 minutes. The power vent must be installed in accordance with the recommendations of the manufacturer, all applicable building code requirements, and NFPA-31.

Vent Dampers

Do not install a thermal type vent damper on the furnace. Failure to comply could result in severe personal injury, death or substantial property damage. If a vent damper is required, use only a motorized damper, wired and installed following the vent damper manufacturers instructions.

Ventilation and Combustion Air

Appliances shall be installed in a location where the facilities for ventilation permit the satisfactory combustion of oil, proper venting and the maintenance of ambient temperature at safe limits under normal conditions of use. The burner requires a generous amount of clean combustion air to operate safely. The furnace room must be well ventilated to allow sufficient make-up air to support combustion.

Inadequate combustion air may result in erratic operation of the burner, noisy combustion or fuel odors in the air. NEVER BLOCK THE FURNACE FROM THE SUPPLY OF COMBUSTION AIR. Remember, your need for outside air will be greatly increased if you have a vented dryer in the basement or other venting fans in the home. Do not install an exhaust fan in the same room as the furnace.

In unconfined spaces in buildings of conventional construction, infiltration is adequate to provide air for ventilation and combustion. If the unconfined space is within a building having insufficient air because of tight construction, the air required for combustion and ventilation shall be obtained from

outdoors or from spaces freely communicating with the outdoors. In this situation, permanent openings having a total free opening area of not less than 1 square inch per 5000Btu/Hr of total input of all appliances must be provided.

If the furnace is located in a confined space (A space whose volume is less than 50 cubic feet per 1000Btu/Hr of the combined input ratings of all appliances installed in that space) the confined space shall have two permanent openings, one 6 inches from the top of the space and one 6 inches from the bottom of the space. Each opening shall have a free area opening of not less than 1 square inch per 1000Btu/Hr of total input rating of all appliances in the enclosure freely communicating with interior areas having adequate infiltration with the outside.

If adequate infiltration air is not available the confined space shall be fitted with two openings, one 6 inches from the top of the enclosure and one 6 inches from the bottom of the enclosure. Each opening shall have a free area of at least 1 square inch per 2000Btu/Hr of the total input of the appliances in the enclosure.

In calculating free area, consideration must be given to the blocking effect of louvers, screens or grills protruding the opening. Screens used shall not be less than 1/4" mesh and shall be readily accessible for cleaning.

Burner Installation

| | |
|--|---|
| NOTICE | Remove the oil burner from its shipping carton and inspect thoroughly. Verify that the correct burner combination and nozzle is installed in the burner as shipped. |
| Read the oil burner manual included in the shipping carton and follow the instructions for preparing and installing the burner. Refer to Table 9, Table 10, or Table 11 for the burner specifications for your unit. | |

On units which can be multi fired, a nozzle change may be required. Follow the oil burner manuals instructions for the proper installation of the nozzle.

Verify that the electrode settings match the manufacturers recommended settings. Inspect the combustion chamber. Verify that it is in the correct position in the heat exchanger and is in good condition.

The oil burner is to be bolted to the pouch plate using the burner mounting flange gasket and the nuts supplied. Make sure that the burner passes through the burner opening in the combustion chamber and does not protrude into the combustion chamber. Refer to the wiring section of this manual for the correct wiring connections to the furnace and to the oil burner manual for fuel piping.

Table 9 Beckett Burner Specifications

| Furnace Model | Burner Model | Delavan Nozzle | Pump Press. | Air Band ¹ | Air Shutter ¹ | Head | Tube Length | Insertion | Static Plate |
|---------------|--------------|----------------|-------------|-----------------------|--------------------------|------------------|-------------|-----------|--------------|
| LB/HB85 | AFG | 0.65X80°A | 140 | 0 | 7 | F-3 ² | 9" | 5-5/8" | 3-3/8 |
| LB/HB115 | AFG | 0.85X80°A | 140 | 0 | 8 | F-4 | 9" | 5-5/8" | 3-3/8 |
| LB/HB145 | AFG | 0.90X80°A | 175 | 0 | 7 | F-6 | 9" | 5-5/8" | 2-3/4 |
| LB/HB160 | AFG | 1.00X80°A | 175 | 0 | 10 | F-6 | 9" | 5-5/8" | 2-3/4 |

Notes: 1. Approximate air settings, see start up procedures for final adjustments.
 2. Low Firing Rate Baffle installed.

Table 10 Riello Burner Specifications

| Furnace Model | Burner Model | Nozzle | Pump Press. | Air Setting ¹ | Turbulator Setting | Tube Length | Insertion |
|---------------|--------------|-----------|-------------|--------------------------|--------------------|-------------|-----------|
| LB/HB85 | 40F3 | 0.65X60°W | 160 | 4.50 | 0.5 | 8-7/8" | 5-3/4" |
| LB/HB115 | 40F3 | 0.85X60°W | 160 | 3.25 | 2.0 | 8-7/8" | 5-3/4" |
| LB/HB145 | 40F3 | 1.00X60°W | 160 | 3.75 | 3.0 | 8-7/8" | 5-3/4" |
| LB/HB160 | 40F5 | 1.10X60°W | 160 | 6.00 | 3.0 | 8-7/8" | 5-3/4" |

Notes: 1. Approximate air settings see start up procedures for final adjustments
2. Burner Amulet Required

Table 11 Carlin Burner Specifications

| Furnace Model | Burner Model | Nozzle | Pump Press. | Air Band ¹ | Air Bar ¹ | Tube Length | Insertion |
|---------------|--------------|------------------------|-------------|-----------------------|----------------------|-------------|-----------|
| LB/HB85 | EZ-1 | 0.65X70°W ² | 140 | 0.65 | 0.60-0.65 | 9" | 5-3/4" |
| LB/HB115 | EZ-1 | 0.85X70°B ² | 140 | 0.85 | 0.85-1.00 | 9" | 5-3/4" |
| LB/HB145 | EZ-1 | 1.00X70°B ² | 140 | 1.00 | 0.85-1.00 | 9" | 5-3/4" |
| LB/HB160 | EZ-1 | 1.10X70°B ² | 140 | 1.10 | 1.10-1.25 | 9" | 5-3/4" |

Notes: 1. Approximate air settings - see start up section for final adjustments
2. Delavan nozzle 3. Hago nozzle

Wiring

WARNING

Electric shock hazard can cause severe personal injury or death if power source, including service switch for the furnace, is not disconnected before installing or servicing the unit.

All wiring must conform to the National Electrical Code NFPA 70, latest edition and any additional state or local codes.

All wiring must be N.E.C. Class 1. If original wiring as supplied with the furnace must be replaced, replace with type 105° C wire or equivalent only.

Power

Supply wire for the furnace must be sized for the load requirement as listed on the furnace rating plate.

Connect 120 VAC 60HZ single phase separate electrical line from the main house panel to the power leads in the junction box attached to the furnace as indicated in the electrical wiring diagrams. Provide a fused disconnect in the power line following all code requirements. Connect the burner to the factory wired burner harness as shown in the electrical diagrams.

Provide electrical ground at the furnace as required by codes.

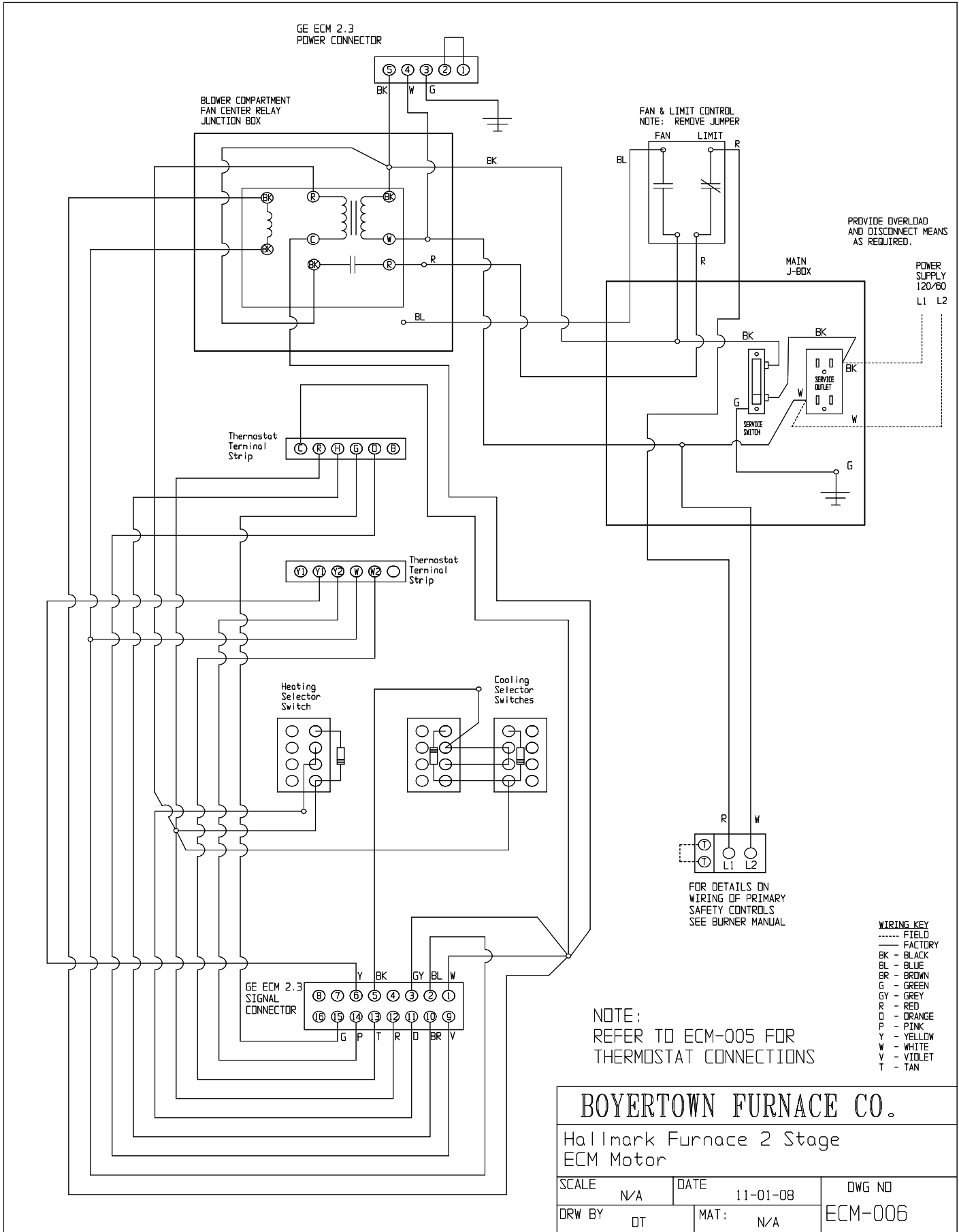

BOYERTOWN FURNACE CO.

Hallmark Furnace 2 Stage
ECM Motor

| | | | | | |
|--------|-----|------|----------|---------|--|
| SCALE | N/A | DATE | 11-01-08 | DWG NO | |
| DRW BY | DT | MAT: | N/A | ECM-006 | |

Thermostat Wiring Connections

All thermostat connections are to be made on the air flow switch plate terminal strip. For ease of installation this should be done before attaching flue piping. A jumper must be installed between the “T-T” terminals on the oil burner.

When installing AC only a wire needs to be run from “Y/Y1” to the “O” terminal for optimum dehumidification.

When installing AC/HP the “O” terminal is for reversing valve energized for AC operation, the “B” terminal is for the reversing valve energized for HP operation.

When wiring for the first stage cooling choose the appropriate “Y1” terminal for the air flow required.

When installing a thermostat incorporating a humidistat it must be configured to break on high humidity. The humidistat will cause the blower to run at 90% of the desired air flow for improved dehumidification. **A jumper wire must be installed between “R” and “H” if no humidistat is present to dehumidify.**

It is recommended to use a thermostat with an outdoor sensor to make the fuel change over from heat pump to oil instead of a fossil fuel kit.

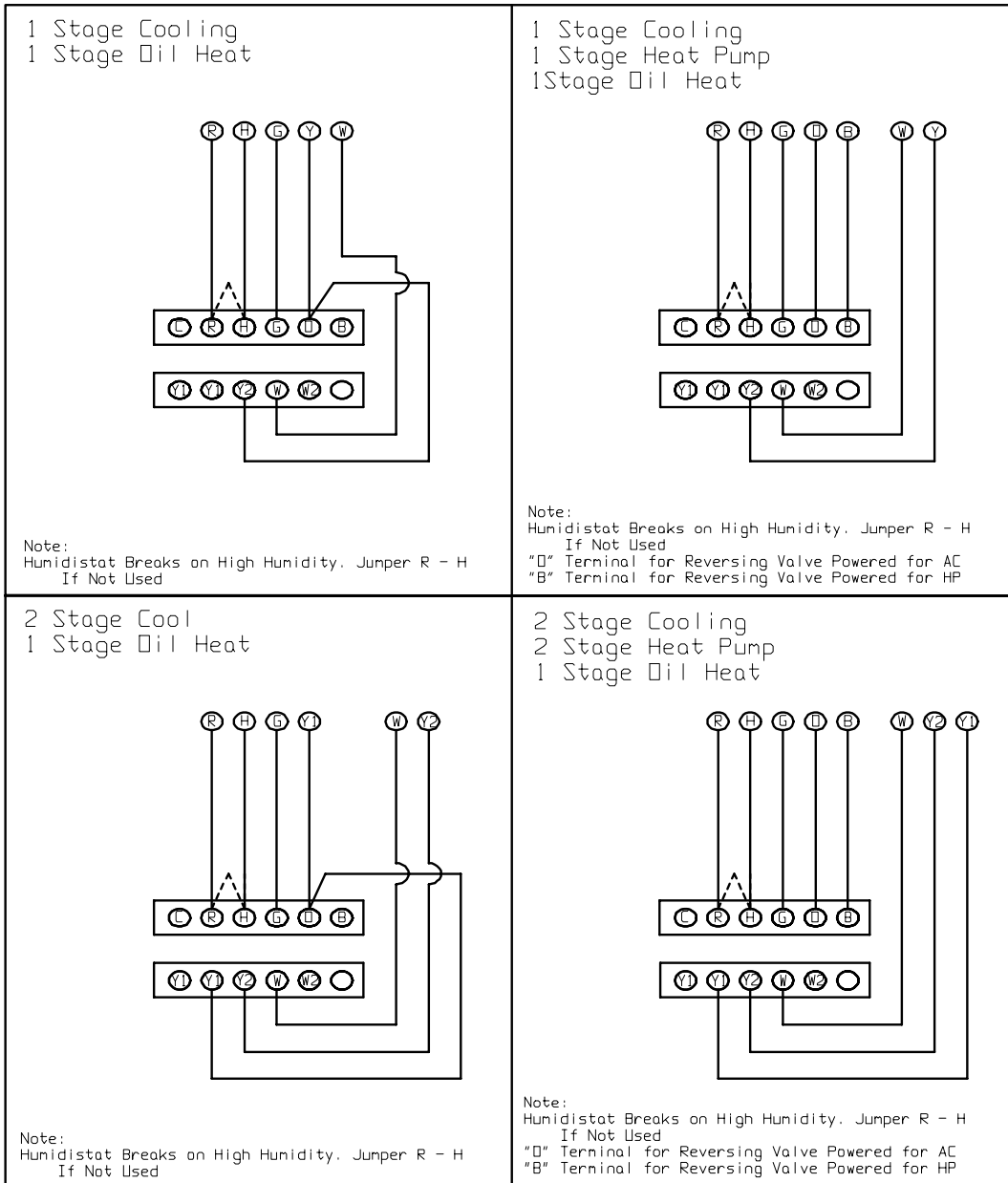

Thermostat Wiring Connections

Locate the room thermostat on an interior wall in the natural circulating path of room air. Do not locate the thermostat so it is exposed to cold air infiltration, drafts from windows or doors, air currents from supply or return air registers, behind obstructions, in a closet or in a corner.

Ensure the thermostat won't be exposed to heat from nearby fireplace, radio, television, lamp or rays from the sun. Do not mount thermostat on a wall over a supply or return duct, chimney or vent.

Oil Tank and Piping

| | |
|----------------|--|
| WARNING | Installation of oil tanks must meet all local codes and ordinances. Refer to NFPA-31 for complete guidelines on oil tank installations internal to the building, outside above and below ground tanks. |
|----------------|--|

Oil tanks located inside the building shall not be in excess of 275 gallons individual capacity and shall not be located within 5 feet horizontally from any source of heat, either internal or external to the appliance being served or in a manner that the temperature of the oil in the tanks exceeds 25°F above room temperature.

Connect burner to oil supply using the correct size heavy wall copper tubing, wrought iron, steel or brass fittings in accordance with the literature attached to the pump. All lines must have shut off valves, a good pipe joint compound approved for use with oil on all pipe threads, no kinks, no sharp bends, and be properly tested for leaks. **Use flare fittings only when assembling oil lines.** Avoid use of fittings in inaccessible locations. Avoid running tubing against any type of heating unit and across ceiling or floor joists. Piping shall be supported and protected from physical damage and where necessary, protected against corrosion as per code. Piping systems shall be maintained liquid tight. A piping system that has leaks constitutes a hazard which must be repaired in an approved manner. All oil feed lines to burners must be air tight. The slightest air leak, caused by loose fittings, bad gaskets or any other reason, can cause a foaming oil stream which will cause any of the following conditions:

- a) Intermittent firing, causing safety shutdown.
- b) Poor starts.
- c) Smokey starts.
- d) Continual sooting of furnace and burner parts including the cad cell.
- e) Reduced firing rate, inefficient operation and erratic fire pattern.
- f) A dangerous combustion condition, allowing the combustion chamber to fill with a lean mixture (too much air in the oil stream) which could cause a delay in ignition of the fuel mixture until the danger point has been reached.

This fuel unit when connected with a single pipe system is satisfactory only where the oil supply is on the same level or above the burner, permitting gravity flow of oil. When it is necessary to lift oil to the burner, a return line must be connected between the fuel unit and the tank. This requires the insertion of the "bypass" plug in the oil pump. The bypass plug and pump instructions are attached to the pump. Installation of a check valve in the suction line of a two pipe system is advisable under all circumstances. Be sure the check valve fittings are air tight. If lift exceeds 10 ft. a two-stage pump must be installed with a two pipe system.

If any part of the fuel oil tank is above the burner, an anti-siphon device must be used to prevent the flow of oil in case of an oil line breakage.

Suction vacuum must be held to acceptable limits. **THE VACUUM TEST IS WORTH THE TIME REQUIRED TO MAKE IT.** This problem becomes proportionately larger with underground tanks. Connect vacuum gauge to oil pump. Suction vacuum must not exceed 10 inches of mercury for single stage pumps and 15 inches for two stage pumps. It is preferable to stay below these limitations. When the suction line is tight and properly installed the pump will hold its vacuum for a minimum of 60 minutes after shutdown.

Use an oil filter with the proper capacity to filter for all installations. Install the filter inside the building between the tank shutoff valve and the burner. The filter cartridge should be replaced at least once a year. The filter body should be thoroughly cleaned before installing a new cartridge.

Start-Up

WARNING Use number No. 2 fuel oil only.

Do not attempt to start the burner if excess oil has accumulated.

Do not use gasoline, crankcase draining or any oil containing gasoline.

This equipment must be adjusted and started only by a qualified service agency – an individual or agency, licensed and experienced with all codes and ordinances, and who is responsible for the installation and adjustment of the equipment.

1. Check that all safety devices are in place.
2. Check that thermostats are correctly connected and set.
3. Check that the inside of the furnace is free of any fuel residue or foreign materials and that the refractory chamber has not been damaged.
4. Check oil burner nozzle to ensure that the right size and type is installed and tight in the adapter. See preliminary settings for proper nozzle size and type.
5. Check electrode settings, as they may have been jarred out of position during transportation. See oil burner instructions for nozzle and electrode setting
6. Check air setting to ensure that it matches the preliminary air settings as found in Table 9, Table 10, or Table 11.
7. Check that the Burner mounting bolts are tight.
8. Lubricate burner motor and circulator motor if required.
9. Open all oil lines valves.
10. Set room thermostat to call for heat.
11. Turn service switch on. Burner should start. On one pipe fuel system only you may have to bleed the oil system. To bleed attach a clear plastic tube to the oil pump bleed port and allow oil to run until all the air is out of the oil suction line feeding the oil burner. If air is still evident in the bleed line you must check the oil lines, all fittings, filters and any other connections for tightness. See burner and fuel pump manufacturers recommendations for proper bleeding of the fuel system.
CAUTION: DO NOT RUN THE PUMP DRY FOR MORE THAN FIVE MINUTES, AS IRREPAIRABLE DAMAGE MAY RESULT.
12. Turn “OFF” burner and install pressure gauge and vacuum gauge into the proper ports on the pump. See the burner manufacturer’s manual for location of ports.
13. Start burner again and check oil pressure. Adjust if necessary. See oil burner manufacturers’ instructions for pump adjustment.

Start-up Equipment

THE FOLLOWING PROPER COMBUSTION INSTRUMENTS ARE REQUIRED TO DETERMINE PROPER AIR ADJUSTMENTS AND DRAFT WHEN SETTING UP OR SERVICING THE OIL BURNER. DO NOT ATTEMPT TO START UP OR SERVICE THE FURNACE WITHOUT THE PROPER COMBUSTION INSTRUMENTS.

1. Carbon-dioxide (CO₂) or Oxygen (O₂) Analyzer
2. Draft gauge. Scale should read from +.10" W.C. to -.25" W.C.
3. Oil Pressure Gauge 0-200 PSI
4. Stack Thermometer
5. Plenum Thermometer
6. Smoke Test Gun
7. Vacuum Gauge 0-30 in. of Hg
8. Volt meter
9. Amp meter

Burner Adjustments

Allow the burner to operate for at least 10 minutes before making the following adjustments. The factory burner settings may not be suitable for specific job conditions.

Do not attempt to make any adjustments or start the furnace without the proper equipment.

1. A 5/16" diameter hole will be required in the flue pipe between the furnace and the barometric damper as close to the furnace as possible.
2. Set the draft regulator (barometric damper) using a draft gauge to obtain a negative draft over-fire of -.01 to -.02 in. W.C.
3. Pump pressure – Install a pump pressure gauge in the oil pump following the oil burner manufacturers' recommendations. Adjust to obtain required pressure as necessary.
4. Combustion Set-up – The air settings shown in Table 8 thru Table 10 are approximate. The burner must be adjusted during actual field installed conditions. Failure to do so will result in poor performance and nuisance service calls. After proper draft and oil pressure have been established:
 - a. Begin to close the air band to create a slight trace of smoke as noted on the Bacharach or equivalent smoke tester scale.
 - b. Take a flue gas sample and note the CO₂ reading. It will be about 12% to 13.5%
 - c. Open the air band to reduce the CO₂ approximately 2%. The desired CO₂ setting for all units should be 10% to 11%
 - d. Check for "0" smoke. Head settings and/or air band may be altered to obtain the above results. Lock the air band and head setting screws in place.

The above procedure will give a built in margin to ensure clean operation throughout the heating season. Should draft conditions vary, lint accumulate in the fan, heavier oil delivered, or other adverse conditions be encountered you will have a reasonable margin of built in protection before smoke generation begins.

5. Flue Gas Temperature - The flue gas temperature will vary to some degree depending on BTU inputs, duct design and the air flow across the heat exchanger. The suggested minimum NET stack temperature is 350°F, and the maximum stack temperature is 550°F. The lower the stack temperature, the higher the efficiency; however, stack temperatures under 350°F may cause condensation which in turn may cause metal corrosion.

6. Temperature Rise - Supply air temperature minus return air temperature. The temperature rise across the furnace (operating at steady state conditions) should be approximately 75°F. A higher temperature rise would slightly lower the efficiency. The supply air temperature should be measured in the supply air trunk-line approximately 12 inches down stream of the plenum. **Do not exceed the maximum temperature rise as listed on the furnace nameplate.**
7. Check operation of the cad cell relay by removing cad cell wire from external terminal of primary safety control to ensure that it goes off on safety.
8. Check blower motor amperage under both heating and air conditioning loads and ensure that the amperage is less than the full load nameplate amperage of the blower motor.

Operating and Maintenance Instructions

WARNING

The furnace must be installed, adjusted and maintained only by a qualified service agency annually. Have your unit inspected, cleaned and adjusted at least once a year to assure proper operation. Do not tamper with the unit or controls. Incorrect operation of the unit could result in severe personal injury and property damage.

Never attempt to use gasoline in the furnace.

Never store gasoline or other combustible materials near the burner or appliance. The area around the furnace should be kept clear of all combustible materials.

Never attempt to burn garbage or refuse in the furnace.

Never attempt to light the furnace by throwing burning material into the furnace.

Never attempt to use crankcase or waste oil or materials other than the approved fuel oils in this furnace.

Never restrict the air inlet openings to the burner.

Do not attempt to start the furnace when excess oil has accumulated in the chamber or the furnace is full of vapors.

Cleaning

WARNING

Cleaning the heat exchanger must be done yearly by a qualified service technician.

It is important to inspect and clean the heat exchanger once annually or as necessary to remove any build up of soot. A layer of soot on the inside surface of the heat exchanger will result in reduced efficiency.

HB/LB

1. Turn off all power to the furnace.
2. Remove the upper pouch plate and the flue pipe.
3. Lower the combustion baffle
4. Using a soft 2" flue brush, cleaning the upper half of each corrugation of any soot buildup.
5. Inspect heat exchanger and combustion chamber.
6. Place the combustion baffle back to its original position and proceed to clean the lower half with the flue brush.
7. Vacuum any loose debris.
8. Replace the upper pouch plate and flue pipe. Should any of the gaskets break or otherwise not be able to provide an adequate seal, the gasket should be replaced before reassembly.
9. Clean and readjust the oil burner as required.

Oil Burner

| | |
|---------------|---|
| NOTICE | Refer to the oil burner instruction manual provided with the burner for proper maintenance and service. Burner Components: If replacement of burner parts is necessary, always use parts recommended by the manufacturer. Specify part number and description when ordering. |
|---------------|---|

Electrode settings are important for reliable ignition of the oil. Check to be sure the settings are in accordance with the instructions provided in the burner manual.

Nozzles: ANY NOZZLE REPLACEMENT SHOULD BE OF THE EXACT TYPE AS THE ORIGINAL SUPPLIED BY THE MANUFACTURER. Use extreme care in handling nozzles to avoid scratches or dirt that could cause leaks or affect the oil spray pattern.

Perform the combustion checks as per the burner manual and the furnace manual.

Blowers - Direct Drive

Clean inspect blower wheel annually. Lubricate blower motor as per the motors recommendations.

Vent System

Clean and inspect the flue pipe draft regulator and chimney annually as outlined in this manual.

Fuel Oil System

Check oil tank and piping for leaks annually, replacing the oil filter to avoid contamination of the fuel unit and nozzle.

Filters

Air filters should be inspected and replaced if required monthly. The filters supplied with the furnace are disposable and need to be replaced with the exact type and size as supplied. Dirty or clogged air filters will impair the furnace performance and may cause the furnace to shut down or overheat.

Do not add additional filters unless the duct system is sized to allow for the additional pressure drop.

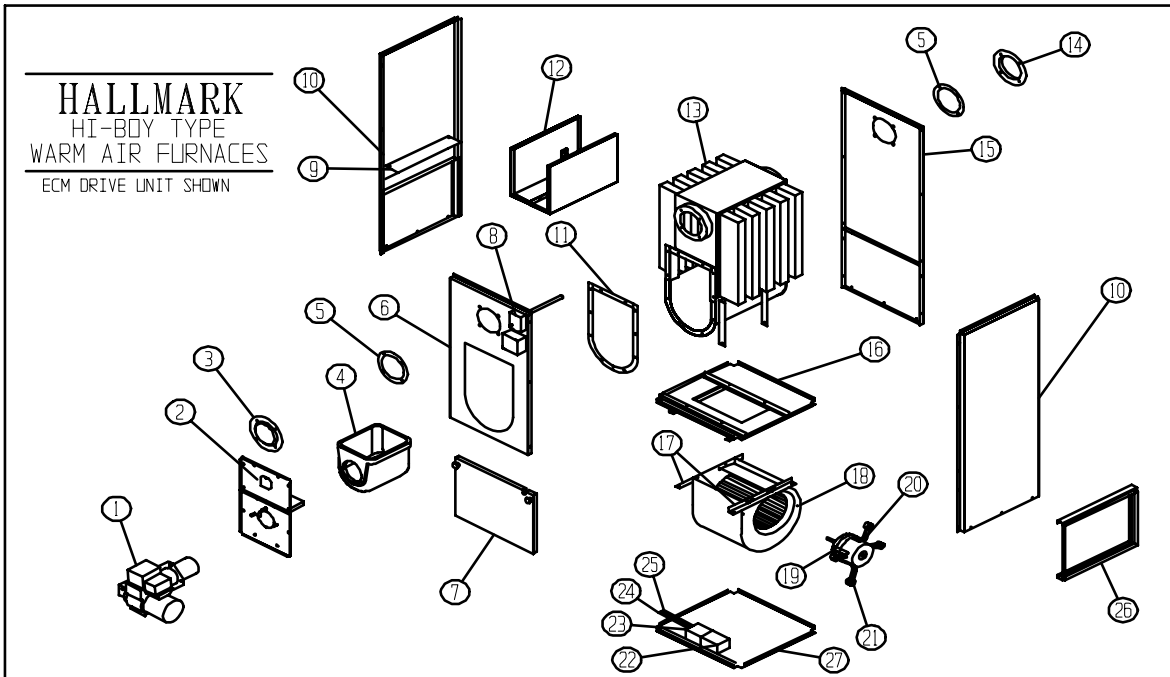

| Item No. | Qty | Description | HBD85 Part No. | HBD115 Part No. |
|----------|-----|---------------------------|----------------|-----------------|
| 1 | 1 | BECKETT BURNER | 540600B | 540601B |
| 1 | 1 | RIELLO BURNER | 540904 | 540901 |
| 1 | 1 | CARLIN BURNER | 540906 | 540907 |
| 2 | 1 | POUCHPLATE ASSEMBLY | 732638 | 732638 |
| 3 | 1 | FLUE COLLAR | 740780 | 740780 |
| 4 | 1 | COMBUSTION CHAMBER KIT | 711301K | 711301K |
| 5 | 2 | FLUE GASKET | 489020 | 489020 |
| 6 | 1 | FRONT PANEL | 504110 | 504510 |
| 7 | 1 | DOOR | 504120 | 504520 |
| 8 | 1 | FAN & LIMIT CONTROL | 552323 | 552323 |
| 9 | 2 | SIDE AIR BAFFLE | 740521 | 740522 |
| 10 | 2 | SIDE PANEL | 504100 | 504500 |
| 11 | 1 | POUCHPLATE GASKET KIT | 489000 | 489000 |
| 12 | 1 | BAFFLE ASSEMBLY KIT | 730317K | 730317K |
| 13 | 1 | HEAT EXCHANGER KIT | 730051K | 730061K |
| 14 | 1 | FLUE COVER | 740800 | 740800 |
| 15 | 1 | REAR PANEL | 504130 | 504530 |
| 16 | 1 | BLOWER PARTITION | 504140 | 504545 |
| 17 | 2 | BLOWER LEG | 740762 | 740762 |
| 18 | 1 | BLOWER | 710401 | 710402 |
| 19 | 1 | BLOWER MOTOR LEG BAND | 710026 | 710026 |
| 20 | 1 | DIRECT DRIVE ECM MOTOR | 712493 | 712493 |
| 21 | 4 | BLOWER MOTOR MOUNTING LEG | 710025 | 710023 |
| 22 | 1 | ECM FAN CENTER RELAY | 552261 | 552261 |
| 23 | 1 | SWITCH PLATE ASSY | 729001 | 729003 |
| 24 | 1 | BLOWER POWER CORD | 729021 | 729021 |
| 25 | 1 | BLOWER CONTROL CORD | 729031 | 729031 |
| 26 | 1 | FILTER RACK | 504160 | 504560 |
| 27 | 1 | BASE PAN | 504150 | 504550 |

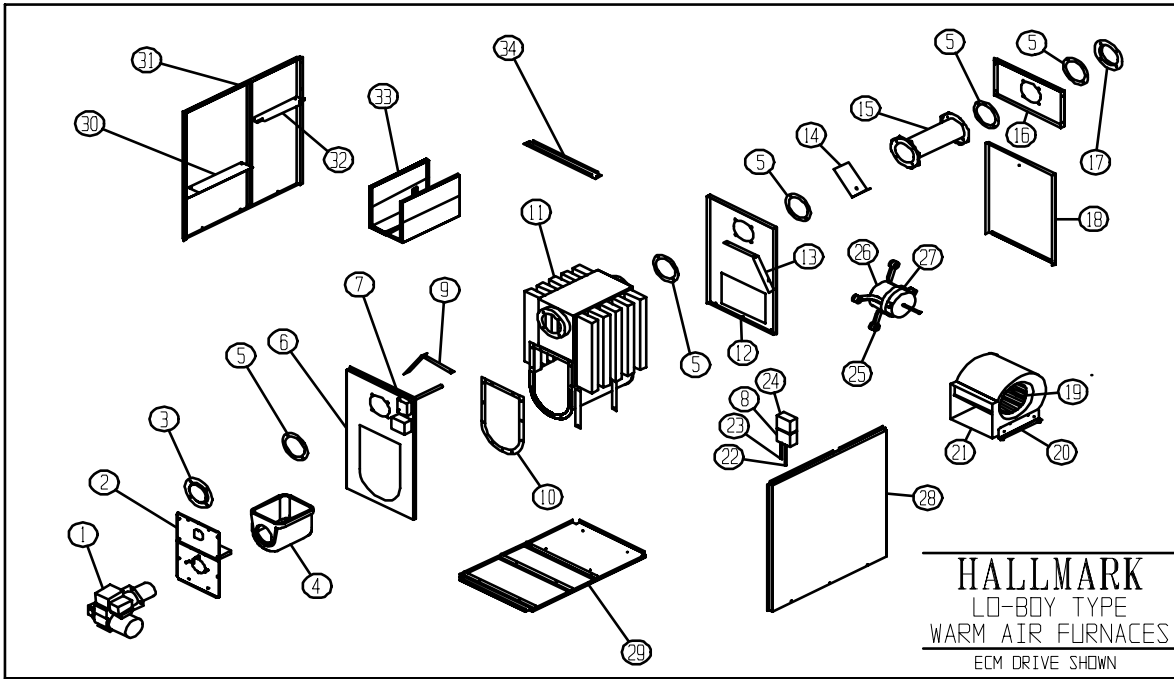

| Item No. | Qty | Description | LBD85 Part No. | LBD115 Part No. |
|----------|-----|---------------------------|----------------|-----------------|
| 1 | 1 | BECKETT BURNER | 540600B | 540601B |
| 1 | 1 | RIELLO BURNER | 540904 | 540901 |
| 1 | 1 | CARLIN BURNER | 540906 | 540907 |
| 2 | 1 | POUCHPLATE ASSEMBLY | 732638 | 732638 |
| 3 | 1 | FLUE COLLAR | 740780 | 740780 |
| 4 | 1 | COMBUSTION CHAMBER KIT | 711301K | 711301K |
| 5 | 5 | FLUE GASKET | 489020 | 489020 |
| 6 | 1 | FRONT PANEL | 504020 | 504420 |
| 7 | 1 | FAN & LIMIT CONTROL | 552323 | 552323 |
| 8 | 1 | ECM FAN CENTER RELAY | 552261 | 552261 |
| 9 | 1 | FRONT AIR BAFFLE | 504900 | 504900 |
| 10 | 1 | POUCHPLATE GASKET KIT | 489000 | 489000 |
| 11 | 1 | HEAT EXCHANGER KIT | 730051K | 730061K |
| 12 | 1 | BLOWER PARTITION | 504060 | 504460 |
| 13 | 1 | LB REAR AIR BAFFLE | 504910 | 504910 |
| 14 | 1 | SEPARATION PLATE | 740763 | 740763 |
| 15 | 1 | FLUE EXTENSION PIPE | 732690 | 732691 |
| 16 | 1 | REAR PANEL | 504030 | 504430 |
| 17 | 1 | FLUE COVER | 740800 | 740800 |
| 18 | 1 | DOOR | 504040 | 504440 |
| 19 | 1 | BLOWER WHEEL | 710356 | 710358 |
| 20 | 2 | BLOWER LEG | 740767 | 740768 |
| 21 | 1 | BLOWER | 710401 | 710402 |
| 22 | 1 | BLOWER POWER CORD | 729020 | 729020 |
| 23 | 1 | BLOWER CONTROL CORD | 729030 | 729030 |
| 24 | 1 | ECM SWITCH PLATE | 729000 | 729002 |
| 25 | 4 | BLOWER MOTOR MOUNTING LEG | 710025 | 710023 |
| 26 | 1 | ECM MOTOR | 712493 | 712493 |
| 27 | 1 | BLOWER MOTOR LEG BAND | 710026 | 710026 |
| 28 | 1 | RIGHT SIDE PANEL | 504000 | 504400 |
| 29 | 1 | BASE PAN | 504070 | 504470 |
| 30 | 2 | SIDE AIR BAFFLE | 740521 | 740522 |
| 31 | 1 | LEFT SIDE PANEL | 504010 | 504410 |
| 32 | 2 | FILTER RACK CHANNEL | 504080 | 504480 |
| 33 | 1 | BAFFLE ASSEMBLY KIT | 730317K | 730317K |
| 34 | 1 | TOP CHANNEL | 504050 | 504450 |

Troubleshooting Guide

WARNING This equipment must be serviced, adjusted and started only by a qualified service agency – an individual or agency, licensed and experienced with all codes and ordinances, and is responsible for the installation and adjustment of the equipment.

Burner Goes Off on Safety

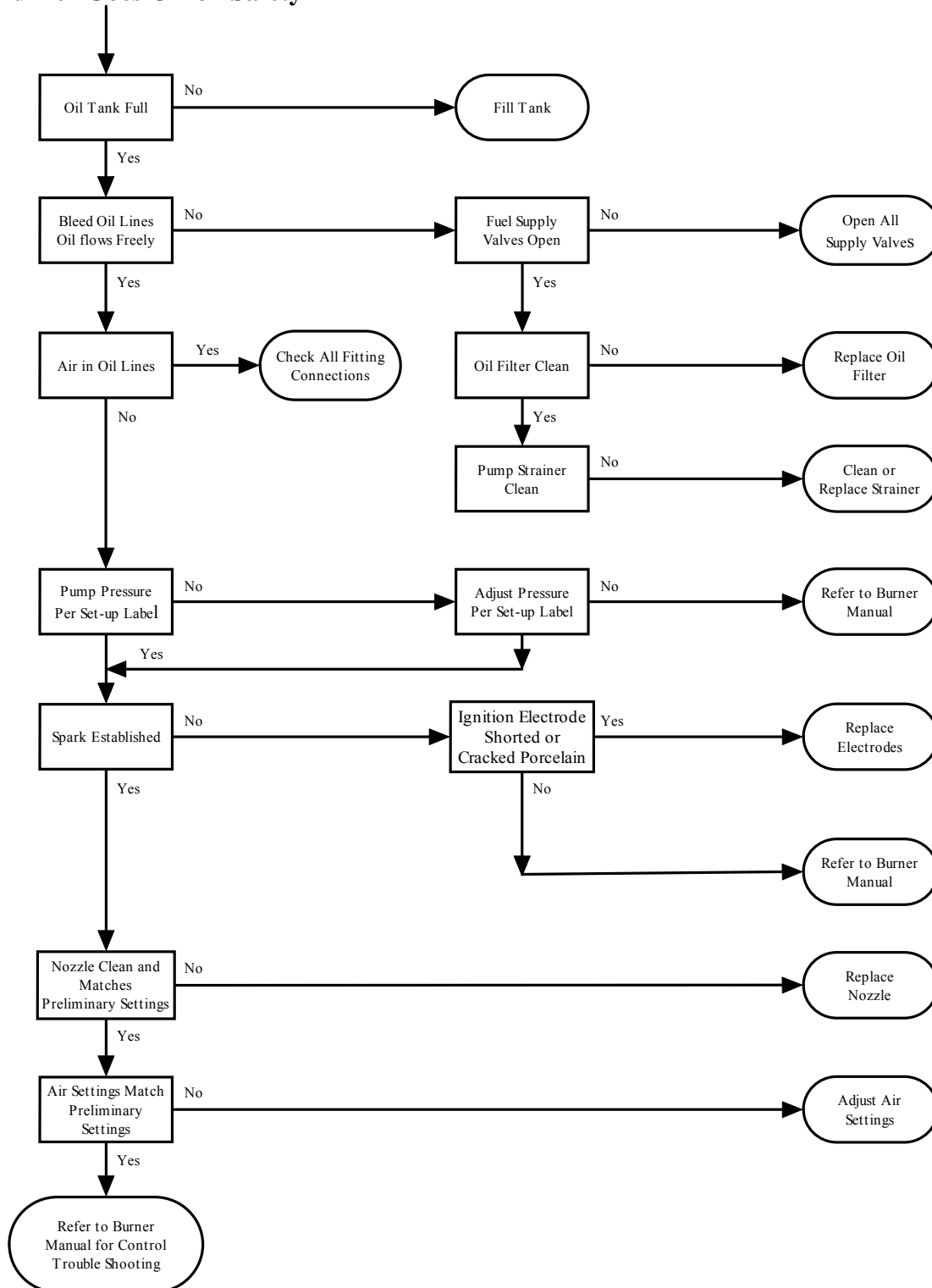

Burner Will Not Start

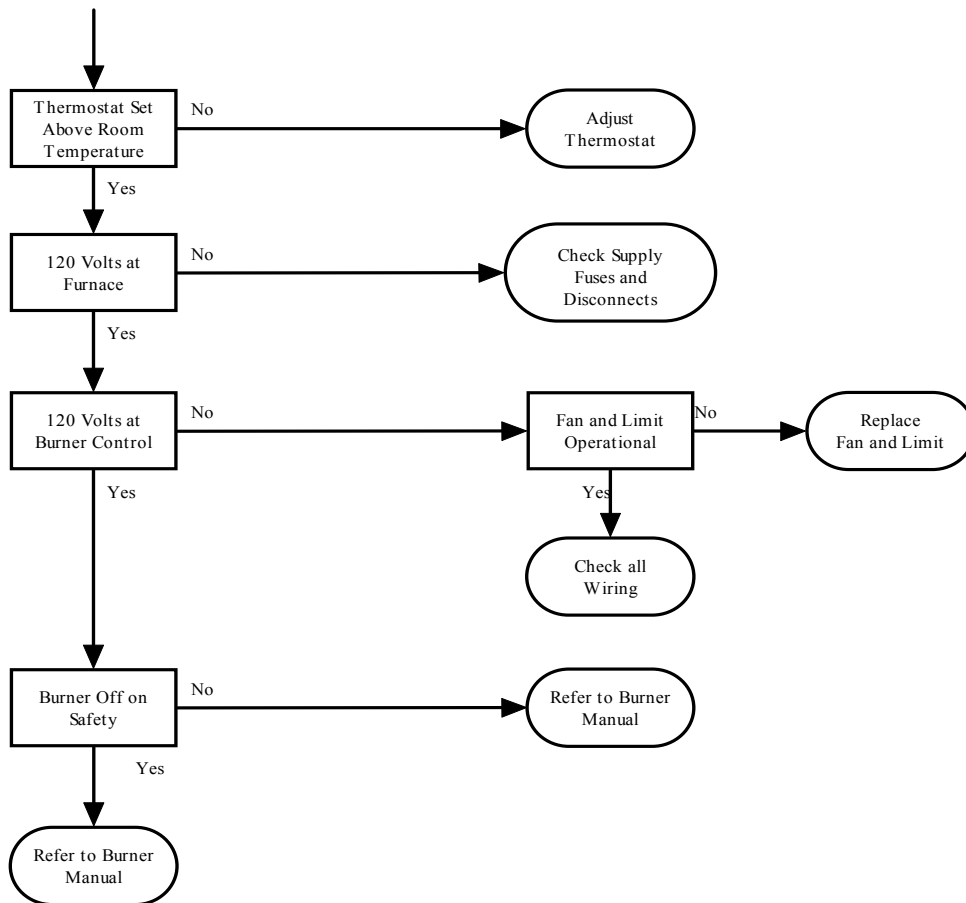

Blower Motor Will Not Run

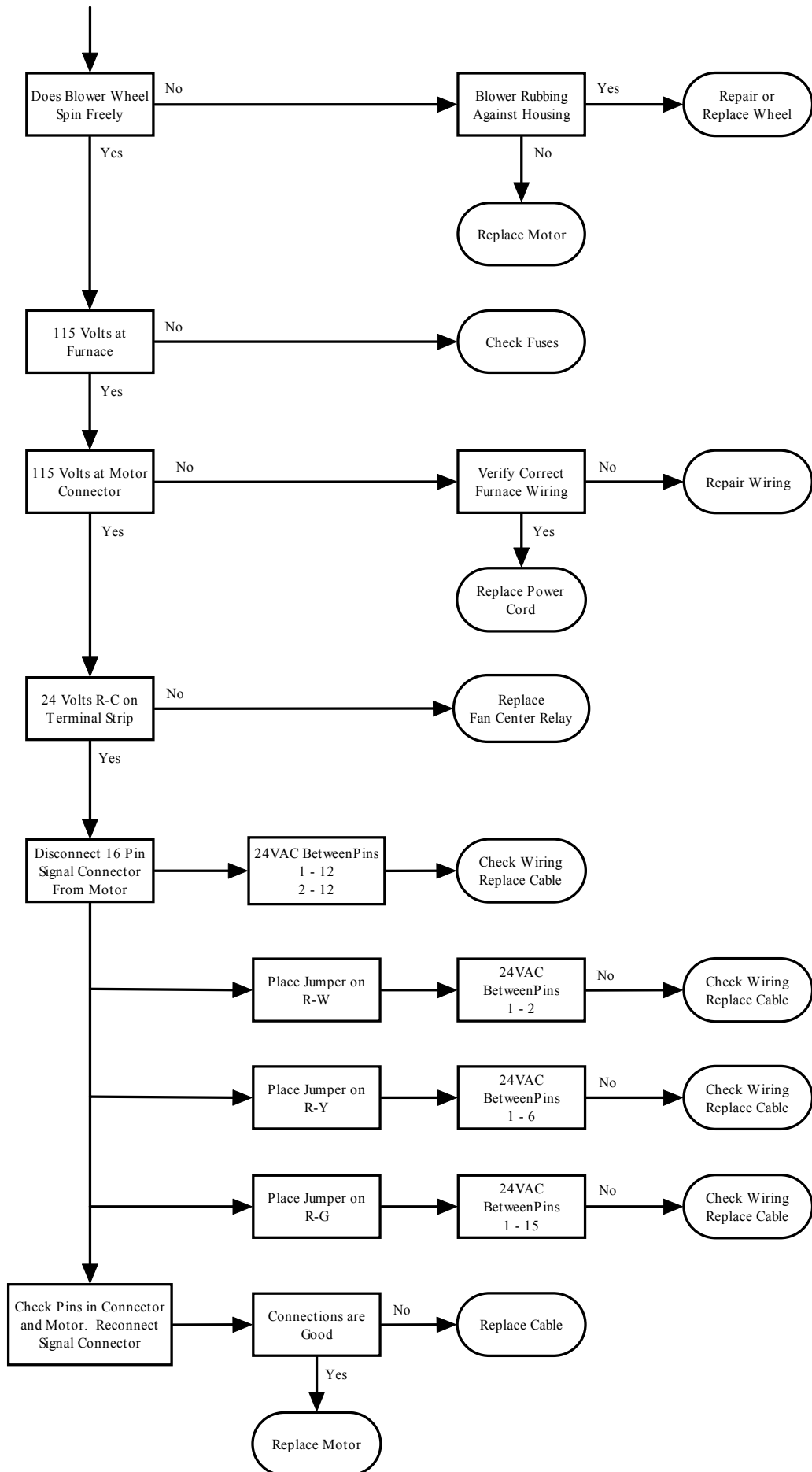

Boyertown Furnace Limited Warranty

Boyertown Furnace Company, Inc. ("Boyertown") hereby warrants to the original consumer purchaser ("Purchaser") that all equipment manufactured for and bearing Boyertown's nameplate to be free from defects in workmanship or material for a period of years as indicated below under normal use and service at a firing rate of number (2) oil not exceeding that shown on its rating plate on all models of Boyertown Furnace. If any such equipment sold by Boyertown proves to be defective in workmanship and material and if such part is within the indicated months below from the date of original installation returned to our factory, transportation charges prepaid, said part will be replaced or repaired, free of charge, F.O.B. Factory. **Purchaser's remedy shall be limited to such repair or replacement and shall be purchaser's exclusive remedy.**

The purchaser, by acceptance of this equipment, will assume all liability for the consequences of its use or misuse by the purchaser, his employees, and all other persons. All warranties are based upon the return of the defective part to the Factory for examination, and purchaser shall assume responsibility and liability for transportation and labor costs.

Boyertown shall not be liable for any consequential damages resulting from breach of this or any other warranty, express or implied. Some states do not allow the exclusion or limitations on relief such as incidental or consequential damages, so the above limitation or exclusion may not apply to you. Some states do not allow limitations on how long an implied warranty lasts, so the above limitation may not apply to you.

| Model | Warranty Period Years | Warranty Period Months |
|----------|-----------------------|------------------------|
| Hallmark | 5 | 60 |
| Regal | 1 | 12 |

Heat Exchanger – Residential Single Family Limited Warranty

In addition to the above limited warranty, Boyertown warrants to the original consumer purchaser at the original installation address in a single family dwelling a limited "lifetime" warranty and adjustment policy on the heat exchanger. In the event that any defect in material and workmanship is found to exist by Boyertown Furnace Company within twenty years (20) of the original installation, Boyertown Furnace Company will at its option, with the serial number and proof of purchase by the original consumer purchaser, furnish a replacement, or repair the heat exchanger. In the event that any defect in material and workmanship is found to exist by Boyertown Furnace Company after twenty (20) years of the original installation, Boyertown Furnace Company will at its option, with the serial number and proof of purchase by the original consumer purchaser, provide a new heat exchanger at fifty percent (50%) of the then current list price, or allow a credit in the amount of fifty percent (50%) of the then current list price of an equivalent heat exchanger toward the list price purchase of an equivalent manufactured Boyertown Furnace Company unit. Proof of purchase will be required of the original purchaser when the claim is made. The purchaser must pay all other costs of warranty services, including labor costs involved in diagnostic calls, or in removing, servicing, or replacing warranty parts and or freight charges.

Heat Exchanger – Commercial Limited Warranty

In addition to the above limited warranty, Boyertown warrants to the original consumer purchaser at the original installation address, being other than a single family residence a ten (10) year warranty on the heat exchanger. In the event that any defect in material and workmanship is found to exist by Boyertown Furnace Company within ten years (10) of the original installation, Boyertown Furnace Company will at its option, with the serial number and proof of purchase by the original consumer purchaser, furnish a replacement, or repair the heat exchanger. Proof of purchase will be required of the original purchaser when the claim is made. The purchaser must pay all other costs of warranty services, including labor costs involved in diagnostic calls, or in removing, servicing, or replacing warranty parts and or freight charges.

Any Implied warranty relating to the heat exchanger covered by this warranty, including that of merchantability and fitness for a particular purpose shall be limited to the period of this limited warranty.

Boyertown shall not be liable for any consequential damages resulting from breach of this or any other warranty, express or implied. Some states do not allow the exclusion or limitations on relief such as incidental or consequential damages, so the above limitation or exclusion may not apply to you. Some states do not allow limitations on how long an implied warranty lasts, so the above may not apply to you.

Purchasers Responsibilities

In the event the original consumer purchaser believes there is a defect in material or workmanship, he shall, within thirty (30) days of the discovery of the defect, notify Boyertown in writing. Boyertown or its authorized representative at its option will inspect the furnace and its component parts to determine whether a defect exists and recommend repair or replacement if necessary under the terms of the warranty. If Boyertown determines that no such defect exists, purchaser may still pursue its remedies by commencing a civil action, but must do so **within (1) year after the cause accrued.** Some states do not allow this (1) year limitation, so it may not be applicable to you.

This warranty will not be applicable if the furnace has been damaged as a result of being improperly serviced, or operated, including but not limited to the following:

- A) If the furnace is used or operated over its rated capacity, as shown on the rating plate, or installed for uses other than residential home heating or commercial heating as listed above.
- B) The furnace not being connected to an adequate sized supply and return air ducts according to industry standards and/or restrictions of air flow through the furnace and duct system.
- C) Furnace must be operated in an environment free from the effects of chlorinated hydrocarbons.
- D) Furnace not being operated during each heating season.
- E) Damages, defects or other losses that occur in anyway after the furnace or heat exchanger has been tampered with, or altered in any way, except as may be specifically directed in writing by Boyertown Furnace Company, and damages, defects or other losses arising from improper installation, adjustment or servicing of the furnace or heat exchanger.
- F) No warranty is given to any equipment which has not been installed by a qualified installer according to the regulations of the National Fire Protection Standard for Oil Burning Equipment, NFPA No. 31 and in complete accordance with all existing local codes, regulations, ordinances, and authorities having jurisdiction. A qualified installer is an individual or agency responsible for the installation and adjustment of oil burning equipment. The installer should be licensed and experienced to perform the installation of such equipment according to all codes and ordinances.
- G) This warranty does not cover expenses for the removal or reinstallation. The purchaser shall be responsible for the cost of removing and reinstalling the defective part including labor and material connected therewith. Upon request of Boyertown, it shall be the obligation of the purchaser to ship prepaid to Boyertown the defective part for inspection or repair.
- H) This warranty is applicable only to defects in material and workmanship and shall not cover failure of the furnace or any of its component parts due to any other reason including, but not limited to (1) lack of sufficient air flow, (2) floods, (3) fire, (4) acts of God, (5) negligent or improper installation, (6) corrosion of heat exchanger surfaces, (7) leaky gaskets, (8) improper maintenance of external and fire side surfaces.

Installation and Service Check List

Furnace Model: _____ Serial No.: _____

Installation Date: _____

Installer Name: _____ Phone No.: _____

Furnace Installation

- Furnace level and in solid contact with floor?
- Furnace and burner wired per wiring diagram and National Electric Code? 120VAC wiring Type _____ Size _____ AWG
- Burner sealed to furnace? Mounting nuts tight?
- Space is large enough to provide required clearances?
- NFPA 31 Installation of Oil Burning Equipment followed?
- Local, state and national codes, laws, regulations and ordinances followed?

Vent System

- Existing chimney and vent system inspected to NFPA 211 and in good condition?
- New vent pipe installed and properly sealed?
- Vent size checked against furnace manual and codes?

Duct Work

- Return and supply ducts checked for size based on furnace air flow and ACCA Manual D?
- All ducts sealed and insulated as required?

Burner Operation

- Burner Model: _____ Nozzle: _____ GPH _____ Deg. _____ Type _____
- Burner Pump Pressure: _____
- Fuel filter and fuel lines installed and inspected as per burner manual?
- Air bled from oil piping? Piping checked for leaks?
- Burner started, adjusted and tested per burner manual?

Furnace Operation

- Thermostat heat anticipator set per burner manual instructions?
- Temperature rise through the furnace checked 75⁰F maximum and blower speed adjusted as required?
- Blower motor amperage does not exceed rated full load amperage?
- Clean air filter installed?
- Limit control tested for proper operation?
- Furnace observed going through several operational cycles for proper operation?

Post Installation

- Reviewed owners' information in this manual with owner or maintenance personnel and instructed to keep for future reference?
- Properly filled in and returned warranty registration card to Boyertown Furnace Co. Inserted burner manual instructions with furnace manual for future use?

PK -----Cut and Return This Form or Register Online at www.boyertownfurnace.com-----

Boyertown Furnace Co.

P.O. Box 100

Boyertown, PA 19512

Date Installed: _____
Furnace Model: _____ Serial Number: _____
Name of Purchaser: _____
Purchaser's Address: _____
Dealer's Name: _____
Dealer's Address: _____